



Foreword



Dear customer,

We are delighted that you have reached for the ABAKUS joinery catalogue. It was specially created to present our products in a completely new light. You are just one step away from making a great decision in your purchase of windows, because the ones that you choose will accompany you for many years, providing warmth, peace and security.

Technical perfection, aesthetics and ergonomics – these are the key criteria to keep in mind when choosing joinery. So let us introduce you to our products and assist you in selecting those that meet your expectations perfectly.

We are ready to serve you with our over quarter century of experience in the production of excellent windows.

Sincerely,
The Board and employees of Abakus Windows

The history of the ABAKUS company dates back to 1994. Originally a small family business, it has been transformed into a leading Polish manufacturer of PVC and aluminium joinery thanks to continuous development. Such an outcome could only have been achieved through the diligent work of a goal-oriented and committed team. The application of the best kinds of raw materials and accessories, the latest trends in technology and quality management are among the main factors contributing to our success. The machine park at the ABAKUS manufacturing plant is one of the most modern in Europe. Unique, cutting-edge engineering allows us to continuously improve the parameters of our products so that they serve their users faultlessly for many years after installation.

Issues related to the aesthetics and design of joinery are a matter of the utmost importance to us. We attentively observe current trends in architecture, making sure that all the goods we provide are fully satisfactory.

Our sales strategy is based on a positive approach. We deeply believe that a good product sells itself. The systematic growth of our share in the European market may serve as proof of the company's constant development and its strong commitment to quality. Customer satisfaction has always been our best motivation for setting and achieving ever more daring goals.

About the company







TECHNOLOGY INSPIRED BY WARMTH

The machine park in which we manufacture ABAKUS windows is a real treasure. We have never hesitated to invest in it. That is why today it belongs to the most modern production plants in the joinery industry in Europe!

Fully automated, innovative ABAKUS production lines operate on the basis of an integrated, ecological management system - IRMC Production®. It is the heart of our factory, thanks to which we can optimize operations, rationalize energy consumption and at the same time constantly improve the parameters of windows and doors, so that they serve without failures for many years. The precision of our machines, combined with durability of profiles always guarantees the same highest quality. Each product that leaves our production hall is perfect in every way. Refined to the last millimeter.

How does it look in practice?

When we receive raw materials at the warehouse, we carefully examine their samples. Each component takes its place in a modern high bay warehouse, so that a fully automated system could easily find it and pass it to our employees in the next production steps.

The digitally programmed process includes: fitting the profiles with the appropriate steel sections, joining them into frames or sashes, strength tests, fitting the hardware, joining the frames with sashes and glazing. All with almost no need for manual handling and repositioning of elements.

The final stage consists of the final inspection, quality approval and proper securing of the product. Thus prepared window we deliver to the indicated address. We ensure optimal logistics, transport of windows on steel stands and their unloading with a lift from the truck.

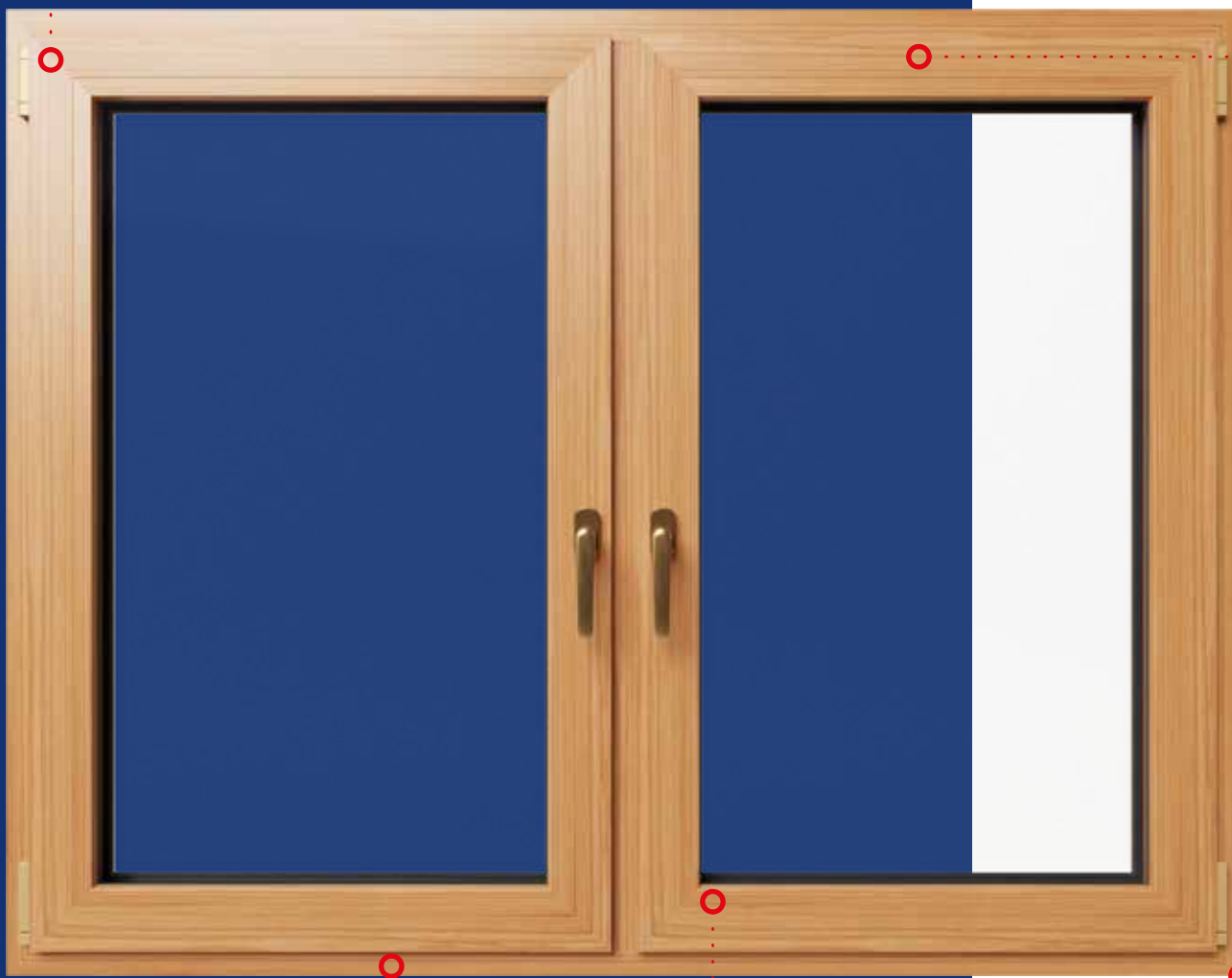

Technology in the service of security

- ◆ Roto NX tilt & turn hardware keeps even 2.6 metre high sashes weighing up to 130 kg! We assemble them as standard in all windows.
- ◆ Handle with Secustik mechanism that makes it impossible to turn it from the outside.*
- ◆ We offer 2 security strikers to each sash as standard.
- ◆ 3 sliding door systems – HST, PSK and SLIDE equipped with special anti-theft hardware. This is the best and the safest exit to the terrace.



*as option

Discover our windows



TECHNOLOGY INSPIRED BY WARMTH

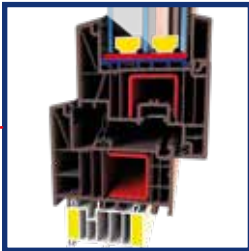

Technology in the service of warmth

- + Effective thermal insulation of our windows is guaranteed by 5 or 6-chamber profiles, airtight insulating glass units, warm edge and additional gaskets.
- + The multi-chamber under-sill bar eliminates frost in this zone and protects the window frame during transport and assembly.
- + Deeply embedded glazing enhances thermal insulation. Innovative technology of glazing bonded with sash improves the rigidity of the window. This is especially important in case of large-sized joinery. *
- + 2 mm galvanized steel reinforcement ensures window rigidity and high resistance to wind and rain.

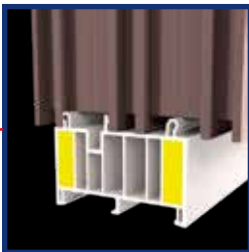

Technology in the service of beauty

- + Our windows are available in many different veneers, including those inspired by wood and metal.
- + Minimalistic line of profiles.
- + Concealed, more aesthetic drainage system. *
- + IRMC technology enabled to obtain an aesthetic weld and a soft gasket in the corners.
- + The precision of our machines combined with durability of profiles gives the effect of always the same, highest quality.
- + Our patio doors - HST, PSK and SLIDE enable opening the house to the garden and spectacular aesthetic effect. At the same time they offer even higher comfort of use and protection against heat loss.



red

redTECH



ABAKUS redTECH are economic, functional and warm windows based on a 73mm profile. RedTECH windows are distinguished by their geometrically simple form with expressive lines, which fits perfectly into modern buildings.

Standard version:

- + white uPVC profile with two black 2-chamber gaskets
- + circumferential fitting with handle and hinge covers in white or brown
- + double glazing with heat transfer coefficient $U_g=1.1 \text{ W/m}^2\text{K}$
- + triple glazing with heat transfer coefficient $U_g=0.6 \text{ W/m}^2\text{K}$ as an option
- + sealed under-sill bar
- + 5-chamber frame and sash profile made of the highest quality uPVC
- + 73 mm frame depth
- + micro-ventilation in Tilt & Turn sashes
- + two security strikers in each sash

Product characteristics available on pages 28/29

Handle characteristics available on pages 30/31

Veneer catalogue available on pages 32/33

Spacer and muntin colours available on pages 34/35

redTECH

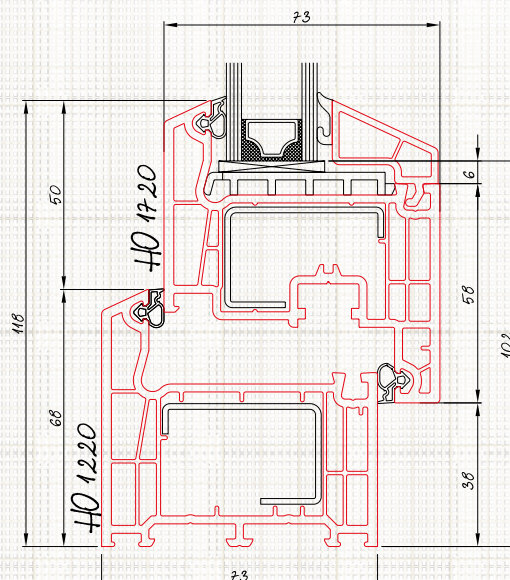

scale 1:2

blu

blu**ENERGY**



bluENERGY is the product of the exclusive passive windows line from ABAKUS. Excellent components and precise machining ensure that bluENERGY windows meet the strict conditions posed before manufacturers of passive designs. Aesthetic minimalism, ergonomics and perfect thermal insulation are qualities that have determined the success of this product. The purchase of bluENERGY windows is a good decision that will leave you satisfied for years.

Standard version:

- + white bluEvolution profile with three black or grey gaskets
- + circumferential fitting with handle and hinge covers in a colour of your choice
- + triple glazing with heat transfer coefficient $U_g=0.5 \text{ W/m}^2\text{K}$
- + warm edge in one of six colours
- + sealed under-sill bar
- + 6-chamber frame and sash profile made of the highest quality uPVC
- + 82 mm frame depth
- + micro-ventilation in Tilt & Turn sashes
- + two security strikers in each sash

Product characteristics available on pages 28/29

Handle characteristics available on pages 30/31

Veneer catalogue available on pages 32/33

Spacer and muntin colours available on pages 34/35

bluENERGY

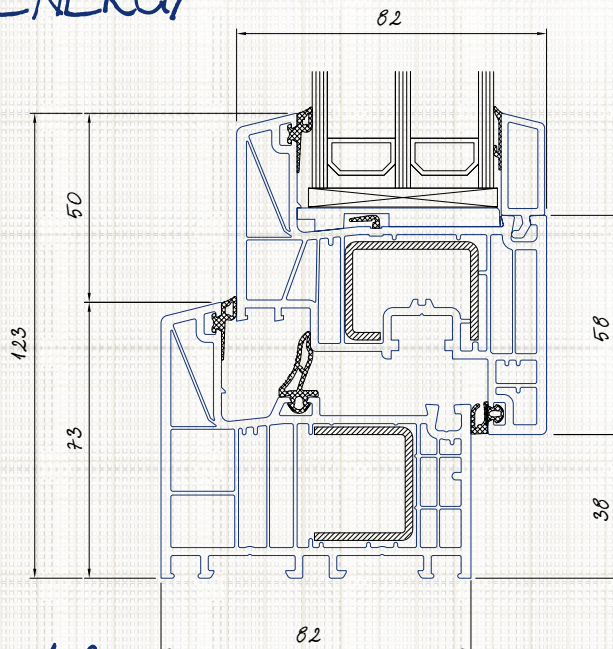

scale 1:2

blu

blu**SYNEGO**



ABAKUS bluSYNEGO is a premium quality product that meets the strict standards of the Passive House Institute. Excellent thermal insulation parameters, resistance to dirt thanks to a unique HDF formula and the possibility of installing the Smart Guard system make bluSYNEGO systems energy efficient, pleasant in maintenance as well as safe for children and the whole family. It is a fulfillment of innovation, reliability and durability for many years.

Standard version:

- + white SYNEGO profile with three black or grey gaskets
- + incredibly smooth external surface, thanks to HDF technology
- + circumferential fitting with handle and hinge covers in a colour of your choice
- + triple glazing with heat transfer coefficient $U_g=0.5 \text{ W/m}^2\text{K}$
- + warm edge in one of six colours
- + sealed under-sill bar
- + 7-chamber frame and 6-chamber sash profiles made of the highest quality uPVC
- + 80 mm frame depth
- + micro-ventilation in Tilt & Turn sashes
- + two security strikers in each sash

Product characteristics available on pages 28/29

Handle characteristics available on pages 30/31

Veneer catalogue available on pages 32/33

Spacer and muntin colours available on pages 34/35

bluSYNEGO

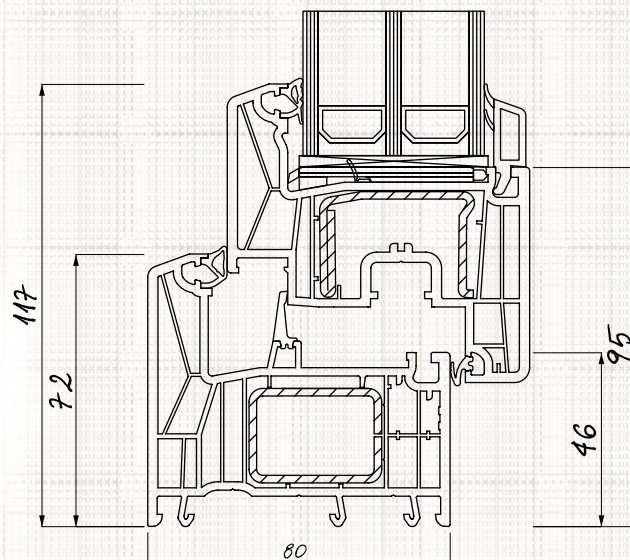

scale 1:2

blu

blu ENERGY GRETA



bluENERGY GRETA

bluENERGY GRETA windows are a unique solution in many aspects. Made of award-winning German Design Award® and Red Dot® mass-dyed Greta®Fenster profiles, are deceptively similar to architectural concrete and fit perfectly into industrial trends. They delight with the natural structure of the surface that can be felt under the fingers and three unique shades. Even when opened, all the visible elements of the frames and sashes are in the same colour.

Standard version:

- + bluEvolution Greta®Fenster profile in 3 colours: light grey, dark grey and black, with black or grey gaskets
- + circumferential fitting with handle and hinge covers in a colour of your choice
- + triple glazing with heat transfer coefficient $U_g=0.5 \text{ W/m}^2\text{K}$
- + colour-matched warm edge
- + sealed under-sill bar
- + 6-chamber frame and sash profiles made of the highest quality uPVC
- + 82 mm frame depth
- + micro-ventilation in Tilt & Turn sashes
- + two security strikers in each sash

Product characteristics available on pages 28/29

Handle characteristics available on pages 30/31

Spacer and muntin colours available on pages 34/35

bluENERGY GRETA

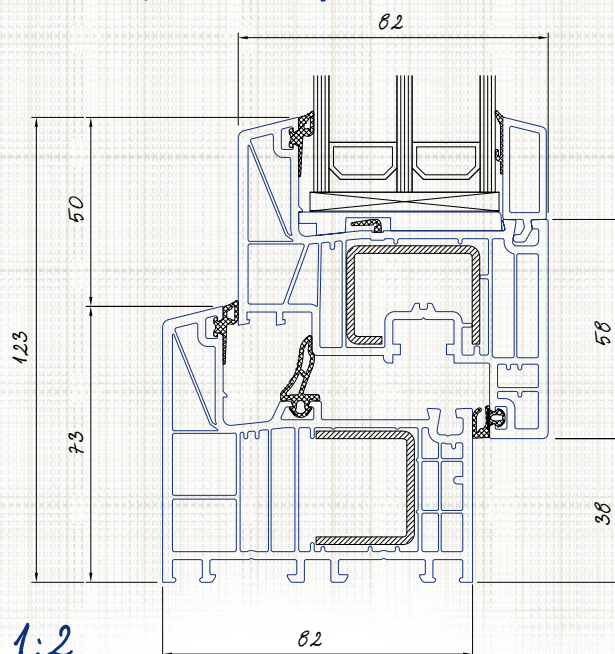

blu



blu**DECORO**

bluDECORO

bluDECORO is our response to the growing interest in all-in-one joinery. It is made of the best profiles, fitted with a special exterior trim bordering the splay. The frame, connected to the elevation finishing trim, creates an aesthetic whole that is available in a wide range of colours. The uniqueness of this product lies in the fact that it can be assembled after the completion of work on the facade. From now on, the splay will no longer be blemished with damp patches and moss.

Standard version:

- + white uPVC profile with three black or grey gaskets
- + circumferential fitting with handle and hinge covers in a colour of your choice
- + triple glazing with heat transfer coefficient $U_g=0.5 \text{ W/m}^2\text{K}$
- + warm edge in one of six colours
- + sealed under-sill bar
- + 82 mm frame depth
- + two security strikers in each sash

Product characteristics available on pages 28/29

Handle characteristics available on pages 30/31

Veneer catalogue available on pages 32/33

Spacer and muntin colours available on pages 34/35

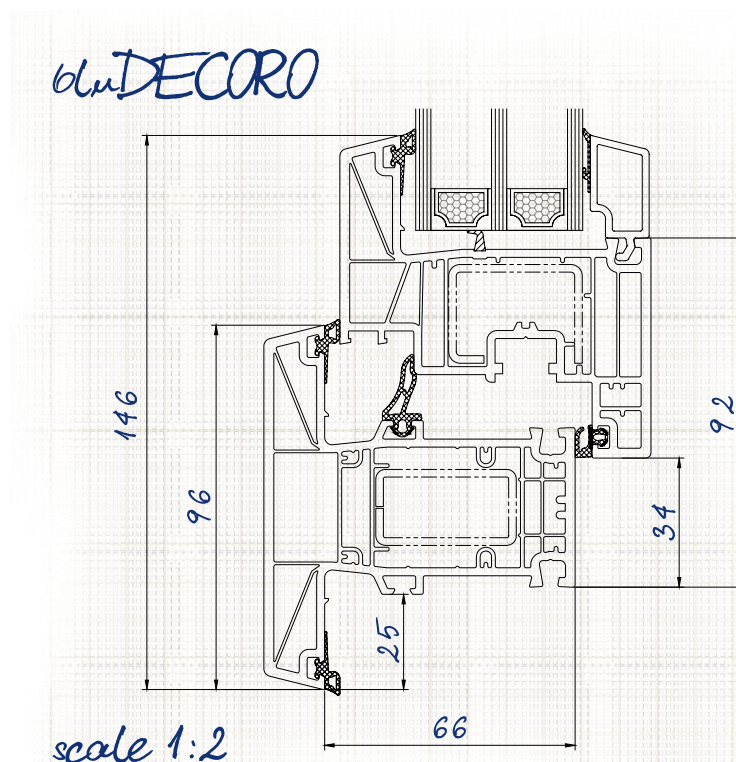

blu



blu**INTERO**

bluINTERO - a brand new window manufactured by ABAKUS that does not require processing of internal embrasure. Its unconventional appearance has been achieved thanks to a trim adhering to the wall and extending beyond the outline of the frame. Sashes of a window made in such technology swing up to a 180 degree angle, which opens up new possibilities in both operation and design. bluINTERO will also work well where we have to deal with narrow wall or a sandwich panel and in cases where it is impossible to make an internal embrasure. Remarkable solutions like this are our hallmark.

Standard version:

- + white uPVC profile with three black or grey gaskets
- + circumferential fitting with handle and hinge covers in a colour of your choice
- + triple glazing with heat transfer coefficient $U_g=0.5 \text{ W/m}^2\text{K}$
- + warm edge in one of six colours
- + sealed under-sill bar
- + 6-chamber frame and sash profile made of the highest quality uPVC
- + 82 mm frame depth
- + micro-ventilation in Tilt & Turn sashes
- + two security strikers in each sash

Product characteristics available on pages 28/29

Handle characteristics available on pages 30/31

Veneer catalogue available on pages 32/33

Spacer and muntin colours available on pages 34/35

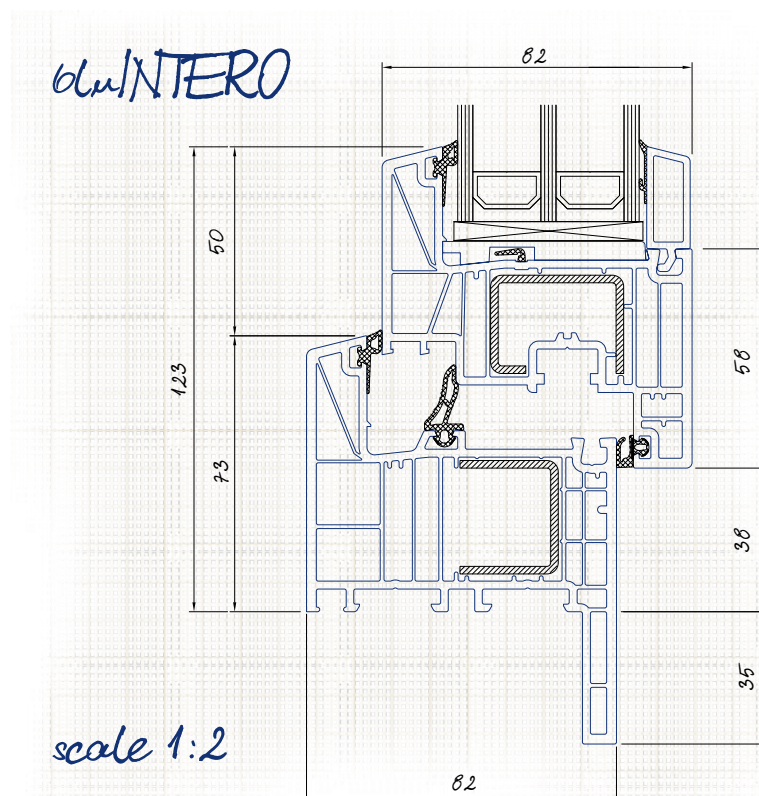

blu

blu**ALU**

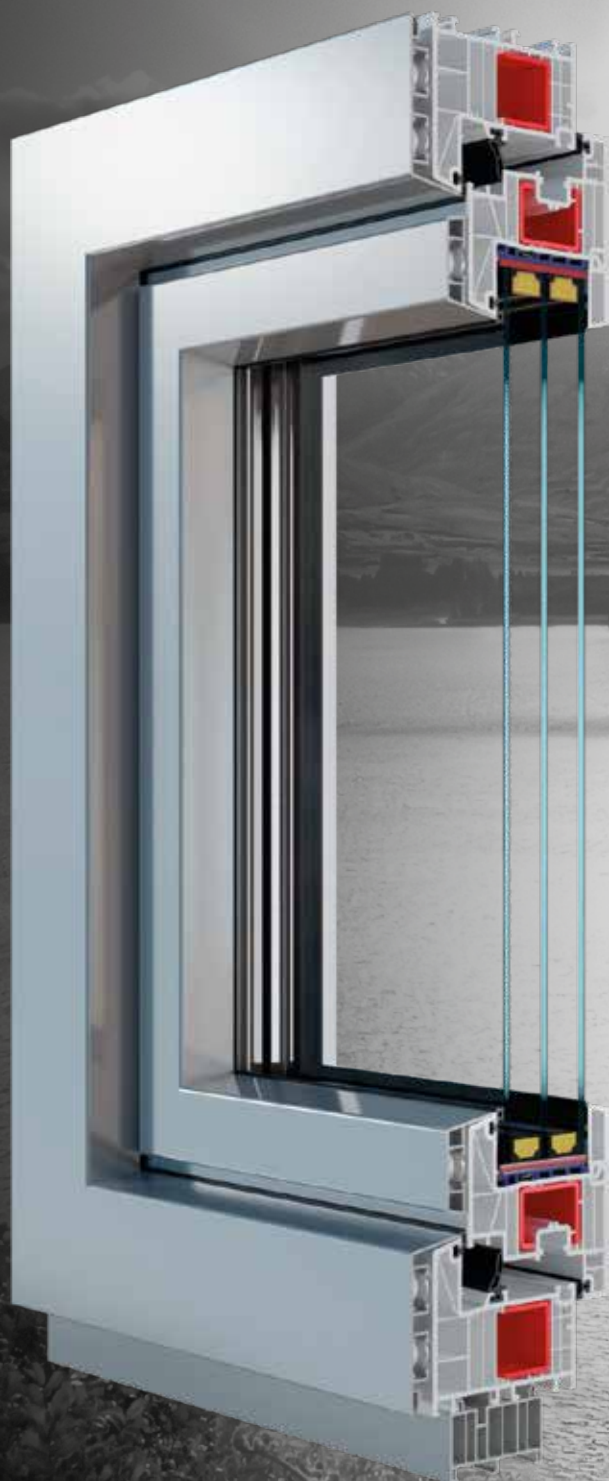

Anyone who wants to maximise the lifespan of their PVC windows should consider installing aluminium clads of our own production. Systems consisting of strips, welded or crimped at the corners, are an effective way to protect joinery against the harmful influence of weather phenomena. Simple installation by means of systemic latches guarantees the independence of both components, PVC and aluminium, from one another. We offer aluminium clads in a wide range of RAL colours - so that everyone can find something suitable.

Standard version:

- + white uPVC profile with three black or grey gaskets
- + circumferential fitting with handle and hinge covers in the colour of your choice
- + triple glazing with heat transfer coefficient $U_g=0.5 \text{ W/m}^2\text{K}$
- + warm edge in one of six colours
- + sealed under-sill bar
- + 6-chamber frame and sash profile made from uPVC of the highest quality
- + 94 mm frame depth
- + micro-ventilation in Tilt & Turn sashes
- + aluminium cladding with latches, powder-coated in one of twenty three colours
- + two security strikers in each sash

Product characteristics available on pages 28/29

Handle characteristics available on pages 30/31

Veneer catalogue available on pages 32/33

Spacer and muntin colours available on pages 34/35

Colours of aluminium clads available on page 36

bluALU

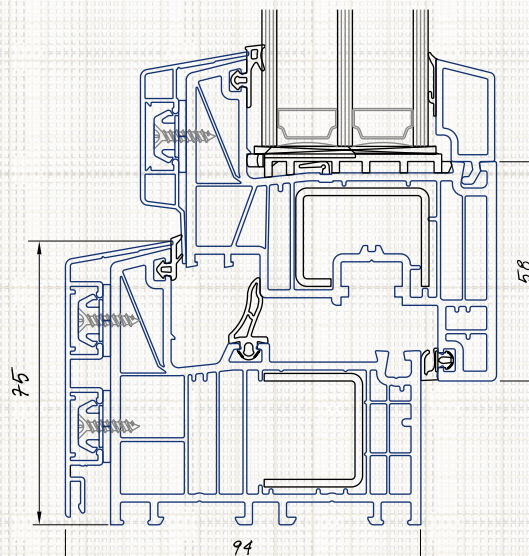

scale 1:2

HS



HS

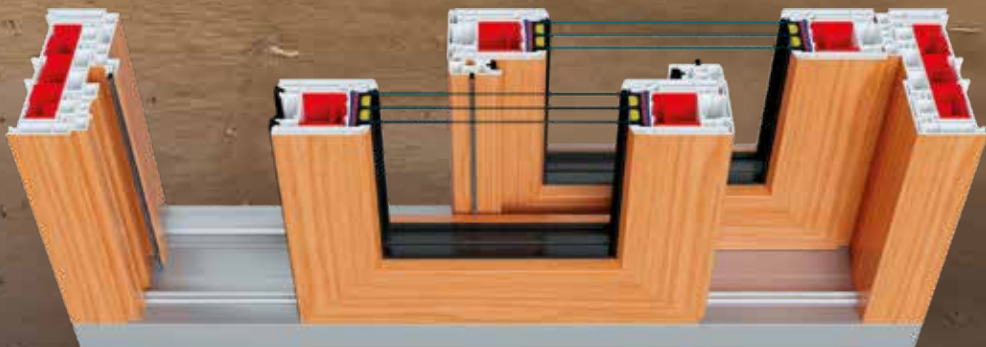

HS

Our proposal for impressive terrace doors is the lift and slide HS system made of PVC. We would like to draw your attention to the ease of sliding the huge door leaves of the HS system, thanks to the application of top quality HS Abakus-portal fittings. A sliding system consisting of carriages moving in aluminium guides is a guarantee of smooth and quiet movement of the system segments. A low, energy-efficient threshold will also make it easier for the disabled to function, and the panoramic sashes ensure perfect lighting for the interiors and facilitate their arrangement due to the space-saving design of the construction. A building equipped with the HS system will be protected against burglary thanks to as many as 4 locking points as standard. So you can sleep well and wake up in a house full of sunshine!

Standard version:

- + white uPVC profile with two black or grey gaskets
- + HS-portal fittings with systemic handle in the colour of your choice
- + triple glazing with heat transfer coefficient $U_g=0.5W/m^2K$
- + warm edge in one of six colours
- + low energy-saving aluminium threshold with increased insulation
- + frame depth 190 mm (Rehau) or 194 mm (Salamander)

Product characteristics available on pages 28/29

Handle characteristics available on pages 30/31

Veneer catalogue available on pages 32/33

Spacer and muntin colours available on pages 34/35

HS Salamander

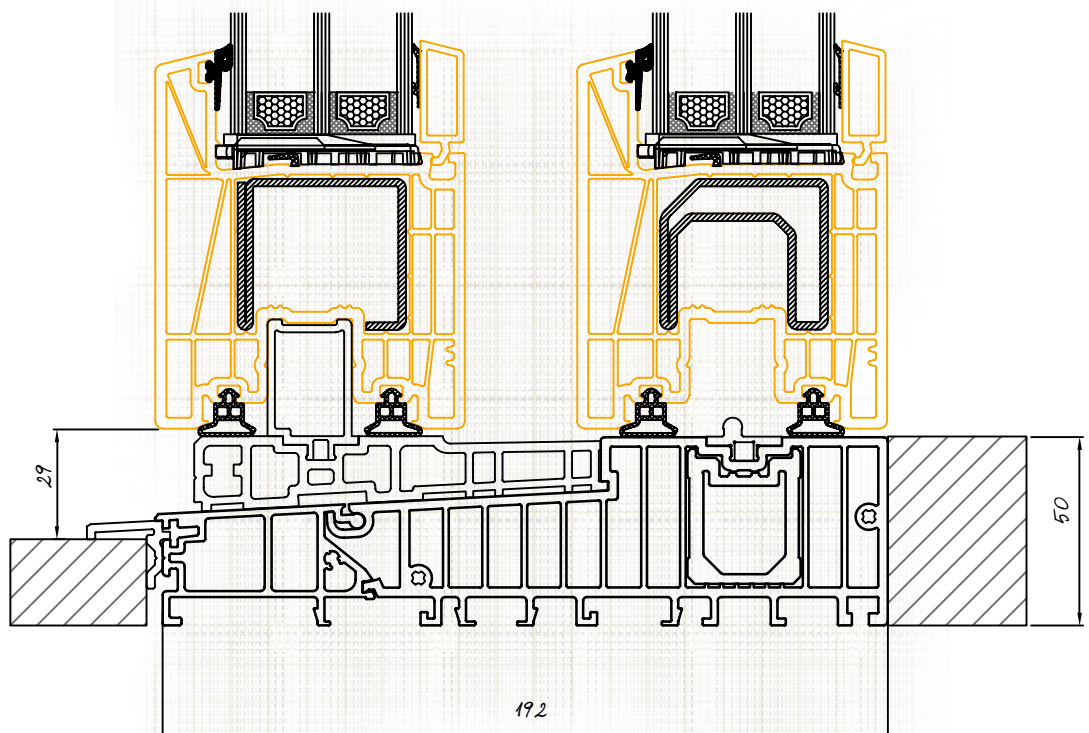

scale 1:2

PSK

PSK



PSK

We present energy-efficient sliding doors with one of the finest ventilation systems. Tilt and slide patio doors PSK, equipped with Roto Patio Alversa system, are available in variants - the KS economical variant equipped with tilt function and in the PS Air COM parallel sliding system, which has a unique ventilation system automatically assisted in the tilt position. Due to the sliding system of the leaves, PSK doors are ergonomic and extremely comfortable to use. Created by them impressive glazing reaching up to 3 metres in width, optically enlarge the interior and add class to it. By choosing PSK doors you gain guarantee of perfect ventilation, illuminated interior and high comfort of use.

Standard version:

- + white PSK profile with gaskets in black or grey
- + triple glazing with heat transfer coefficient $U_g=0.5 \text{ W/m}^2\text{K}$
- + warm edge in one of six colours
- + micro-ventilation
- + frame depth 73 mm or 82 mm (Salamander), 80 mm (Rehau)

Product characteristics available on pages 28/29

Handle characteristics available on pages 30/31

Veneer catalogue available on pages 32/33

Spacer and muntin colours available on pages 34/35

PSK *blue* ENERGY

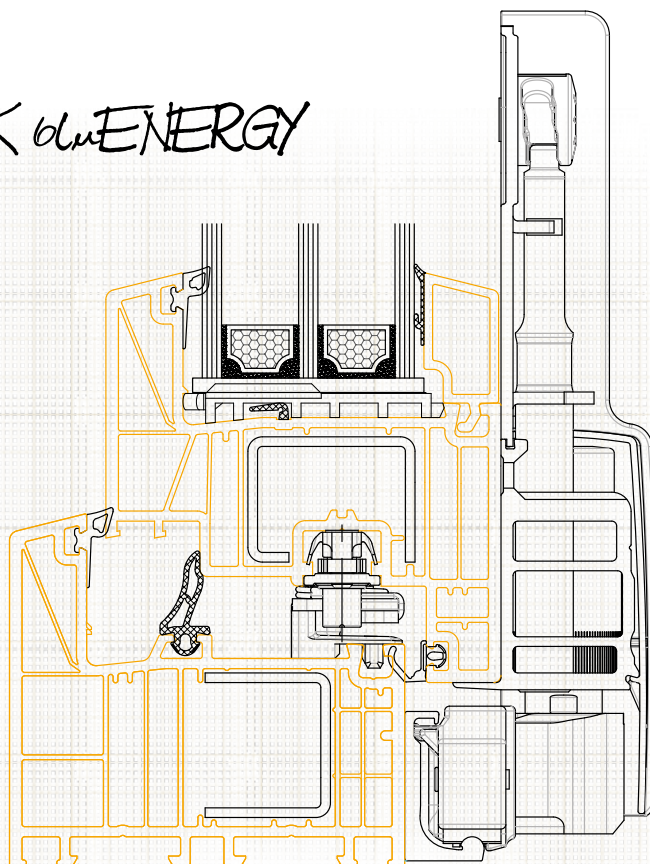

scale 1:2

SLIDE

SLIDE



SLIDE

Here are some of the smartest sliding doors for modern home. Patio door SLIDE is a product in which innovation and modernity are manifested in every parameter and design. Unusual lightness of sliding and new comfort of opening make the door perfect for children and the whole family. On request, we equip them with the SoftClose function, which gently slows the sash during closing and brings it to the end position. Moreover, the SLIDE has excellent thermal insulation properties and enhanced burglary protection. The innovative mechanism also ensures perfect fit of the perimeter gasket for high tightness even during heavy rainfall. With SLIDE door you can enjoy unparalleled warmth, blissful silence and the highest security in your own home.

Standard version:

- + white Slide profile with two black gaskets
- + triple glazing with heat transfer coefficient $U_g=0.5 \text{ W/m}^2\text{K}$
- + warm edge in one of six colours
- + low energy-saving threshold with increased insulation
- + frame depth 152 mm (Salamander), 156 mm (Rehau)

Product characteristics available on pages 28/29

Handle characteristics available on pages 30/31

Veneer catalogue available on pages 32/33

Spacer and muntin colours available on pages 34/35

SLIDE Rehau

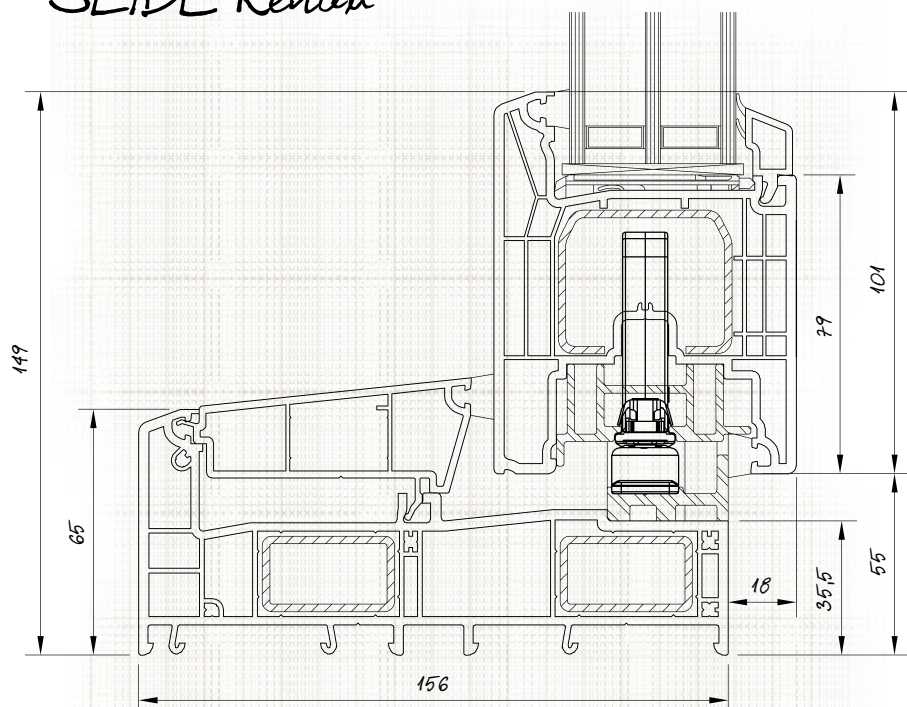

scale 1:2

ABAKUS windows and doors

	red line	blu line		
	redTECH / redARTE	bluENERGY	bluSYNEGO	bluENERGY GRETA
Frame depth	73 mm	82 mm	80 mm	82 mm
5-chamber profiles SALAMANDER bluEvolution 73	✓	✗	✗	✗
6-chamber profiles SALAMANDER bluEvolution 82	✗	✓	✗	✓
6-chamber profiles REHAU SYNEGO 80	✗	✗	✓	✗
EQUIPMENT				
Roto NX fittings	✓	✓	✓	✓
Roto Designo - concealed hinges	○	○	○	○
TiltFirst fittings - child safety system	○	○	○	○
Two security strikers	✓	✓	✓	✓
RC1N burglar inhibiting fittings	○	○	○	○
RC2N burglar inhibiting fittings	○	○	○	○
Lifting Mishandling Device	○	○	○	○
Roto Line Secustik handle	○	✓	✓	✓
Roto Swing Secustic handle	○	○	○	○
Aluminium handle - white or brown	✓	○	○	○
Glass bonded with sash	○	○	○	○
Balcony Bullet Catch	○	○	○	○
Handle Brake-Stay	○	○	○	○
Micro-ventilation in Tilt & Turn sashes	✓	✓	✓	✓
Double glazing 4/16/4 Ug = 1.1 W / m ² k	✓	○	✗	○
Triple glazing 4/16/4/16/4 Ug = 0.6 W / m ² k	○	✗	✗	✗
Triple glazing 4/18/4/18/4 Ug = 0.5 W / m ² k	✗	✓	✓	✓
Spacer bar made of compound insulation material (warm edge)	○	✓	✓	✓
Spacer bar made of steel (warm edge)	✓	○	○	○
Sealed under-sill bar	✓	✓	✓	✓
SOLAR CONTROL GLASS				
Antisol Brown - tinted glass	○	○	○	○
Antisol Green - tinted glass	○	○	○	○
Antisol Grey - tinted glass	○	○	○	○
Stopsol Brown - reflective glass	○	○	○	○
Stopsol Green - reflective glass	○	○	○	○
Stopsol Grey - reflective glass	○	○	○	○
LAMINATED GLASS				
O2 - Safety glass	○	○	○	○
P2 - Burglar-proof glass	○	○	○	○
P4 - Burglar-proof glass	○	○	○	○
SOUND-PROOF GLASS				
39 dB	○	○	○	○
40 dB	○	○	○	○
45 dB	○	○	○	○

✓ - available ✗ - unavailable ○ - optional

characteristics

blu line			HS Rehau/Salamander	PSK			SLIDE Rehau/ Salamander
bluDECORO	bluINTERO	bluALU		redTECH/redARTE	bluENERGY	bluSYNEGO	
82 mm	82 mm	94 mm	190/194 mm	73 mm	82 mm	80 mm	156/152 mm
X	X	X	X	✓	X	X	X
✓	✓	✓	X	X	✓	X	X
X	X	X	X	X	X	✓	X
EQUIPMENT							
✓	✓	✓	X	X	X	X	X
o	o	o	X	X	X	X	X
o	o	o	X	X	X	X	X
✓	✓	✓	X	✓	✓	✓	✓
o	o	o	X	o	o	o	X
o	o	o	X	o	o	o	X
o	o	o	X	X	X	X	X
✓	✓	✓	X	X	X	X	X
o	o	o	X	X	X	X	X
o	o	o	X	X	X	X	X
o	o	o	o	o	o	o	o
o	o	o	X	X	X	X	X
o	o	o	X	X	X	X	X
o	o	o	o	o	o	X	o
X	X	X	X	o	X	X	X
✓	✓	✓	o	X	o	o	o
✓	✓	✓	✓	o	✓	✓	✓
o	o	o	o	✓	o	o	o
✓	✓	✓	X	✓	✓	✓	X
SOLAR CONTROL GLASS							
o	o	o	o	o	o	o	o
o	o	o	o	o	o	o	o
o	o	o	o	o	o	o	o
o	o	o	o	o	o	o	o
o	o	o	o	o	o	o	o
LAMINATED GLASS							
o	o	o	o	o	o	o	o
o	o	o	o	o	o	o	o
o	o	o	o	o	o	o	o
SOUND-PROOF GLASS							
o	o	o	o	o	o	o	o
o	o	o	o	o	o	o	o
o	o	o	o	o	o	o	o

Handle characteristics

Available colours

old gold		black R06.2	
titanium		grey brown R04.1	
silver		old gold R05.5	
brown		titanium matt R01.3	
white		silver R01.1	
		medium bronze R05.3	
		white R07.2	
		anthracite R02.2*	

Handle model

standard	Roto Line Secustik	Roto Line button	Roto Line key

redTECH / redARTE	✓	○	○	○
bluENERGY	✓	○	○	○
bluSYNEGO	○	✓	○	○
bluENERGY GRETA	✓	○	○	○
bluDECORO	○	✓	○	○
bluINTERO	○	✓	○	○
bluALU	○	✓	○	○
HS	✗	✗	✗	✗
PSK	✗	✗	✗	✗
SLIDE	✗	✗	✗	✗

✓ - available ✗ - unavailable ○ - optional

*available for Roto Line Secustik

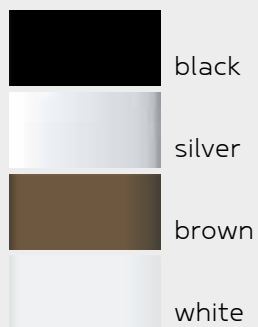

Swing Secustik



Swing button



Swing key



HS standard



PSK/SLIDE

o	o	o	x	x
o	o	o	x	x
o	o	o	x	x
o	o	o	x	x
o	o	o	x	x
o	o	o	x	x
o	o	o	x	x
x	x	x	✓	x
x	x	x	x	✓
x	x	x	x	✓

ABAKUS veneers

SALAMANDER - STANDARD

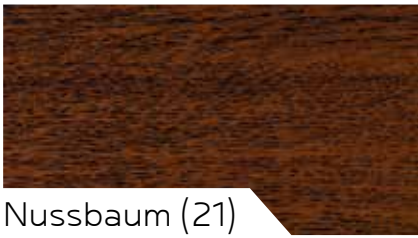

SALAMANDER - HALF STANDARD



SALAMANDER - OPTIONAL



Veneered PVC products have black gaskets.

REHAU - STANDARD



Anthracite Grey (4443)



Dark oak FL-F1 (4914)



Golden oak (7512)



Walnut (225L)



Winchester XA (1208L)



Sapelli (9632)



Anthracite Grey Smooth (930L)

REHAU - HALF STANDARD



Midnight Black Matt (1980L)



Turner Oak malt (2031L)

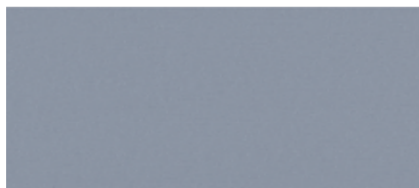

Grey (9922)



Alux DB703 (1642L)



Black Brown (9631)



Irish oak (913L)



Basalt grey (134 L)

REHAU - OPTIONAL



Sheffield Oak concrete (2039L)



Sheffield Oak alpine (2038L)



Metbrush anthracite grey (1392L)



Moos green (4925)



Sheffield oak light (1562L)



Metbrush aluminium (1049L)



Stripe douglas (4404)

AVAILABLE SHAPES

	RECTANGULAR	NON-RECTANGULAR	ARCHED
redTECH / redARTE	✓	✓	✓
bluENERGY	✓	✓	✓
bluSYNEGO	✓	✓	✓
bluENERGY GRETA	✓	✓	✓
bluDECORO	✓	X	X
bluINTERO	✓	X	X
bluALU	✓	✓	X
HS	✓	X	X
PSK	✓	X	X
SLIDE	✓	X	X

✓ - available X - unavailable

DISTANCE SPACER COLOURS

	Aluminium	White	Light grey	Grey	Light brown	Brown	Black
redTECH / redARTE							
bluENERGY							
bluSYNEGO							
bluENERGY GRETA							
bluDECORO							
bluINTERO							
bluALU							
HS							
PSK							
SLIDE							

GLUED-ON MUNTINS

- + muntins dedicated for joinery in historic and stylized buildings
- + made of PVC, with gaskets on the edges and a system of gluing to the glazing
- + may be laminated with the same veneer as the other window elements
- + the glazing cavity covered by a muntin (in case of the 27 mm width) is filled with a duplex spacer - in this way, the same visual effect is achieved as for structural muntins

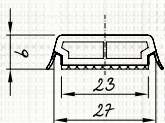

scale 1:2

IN-PANE MILLED MUNTINS

- + placed between glass panes
- + made of aluminium alloy, powder coated in any RAL colour and in any texture
- + available in widths: 18 mm, 26 mm, 45 mm

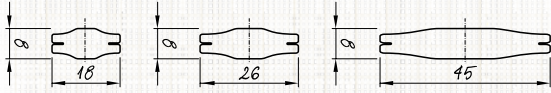

scale 1:2



IN-PANE CLAMPED MUNTINS

- + placed between glazing panes
- + made of aluminium alloy, powder coated in white, gold, old gold and silver
- + connected by using cross-pieces and joint pieces at intersections

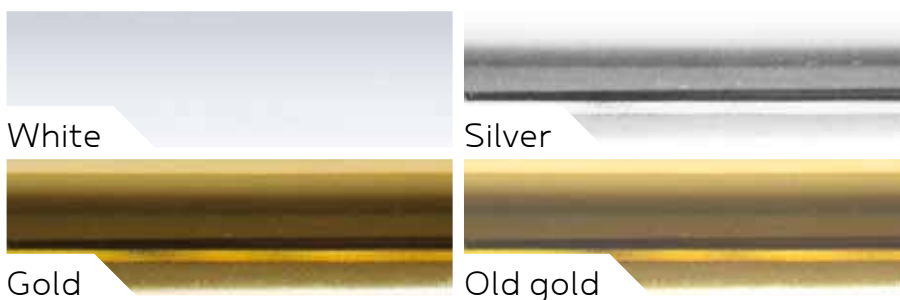

The colours of goods presented in photographs may deviate from the actual appearance of products. Differences between delivered products and their photographs in the catalogue may not serve as grounds for any claim of the customer that the goods do not conform to the order.

Colours

COLOURS OF ALU CLADS bluALU

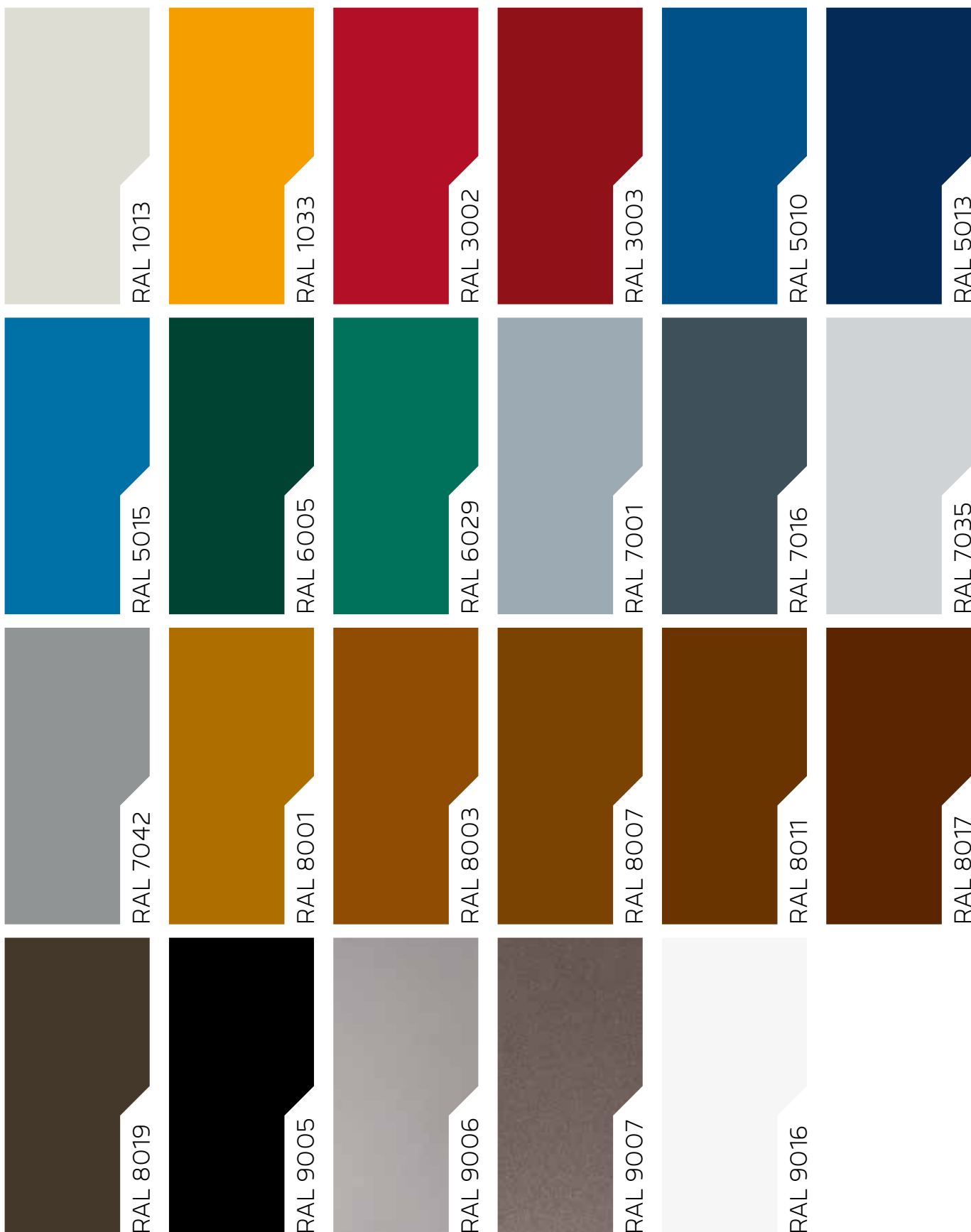

The colours of goods presented in photographs may deviate from the actual appearance of products. Differences between delivered products and their photographs in the catalogue may not serve as grounds for any claim of the customer that the goods do not conform to the order.



ABAKUS OKNA SP. Z O.O.
Aleje Jerozolimskie 100
00-807 Warsaw
POLAND
VAT EU: PL 5252465853

Manufacturing plant
Mickiewicza 76
16-070 Choroszcz
POLAND

tel. +48 85 713 09 70